

-NOTES-

1. MATERIAL:  
ARM: FIBERGLASS TUBE FILLED WITH CLOSED CELL FOAM  
MOUNTING BRACKET & HARDWARE: GALVANIZED STEEL
2. COLOR: GRAY (BROWN OPTIONAL) PAINTED WITH UV INHIBITOR PAINT
3. ALL CROSSARM HOLES COME STANDARD WITH SLEEVES INSTALLED.
4. RECOMMENDED HARDWARE TORQUE: 250 IN-LBS
5. HOLES AVAILABLE IN OPTIONAL SIZES DEPENDING ON CATALOG NUMBER:  
 "CTA": 5/8" HARDWARE  
 "CTF": 3/4" HARDWARE
6. FOR A COMPLETE LIST OF OPTIONS SEE SMART NUMBERING SYSTEM ON SHEET 2

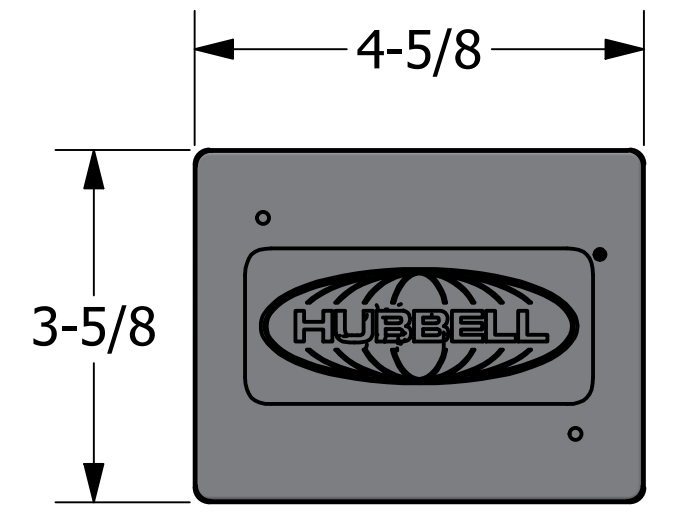

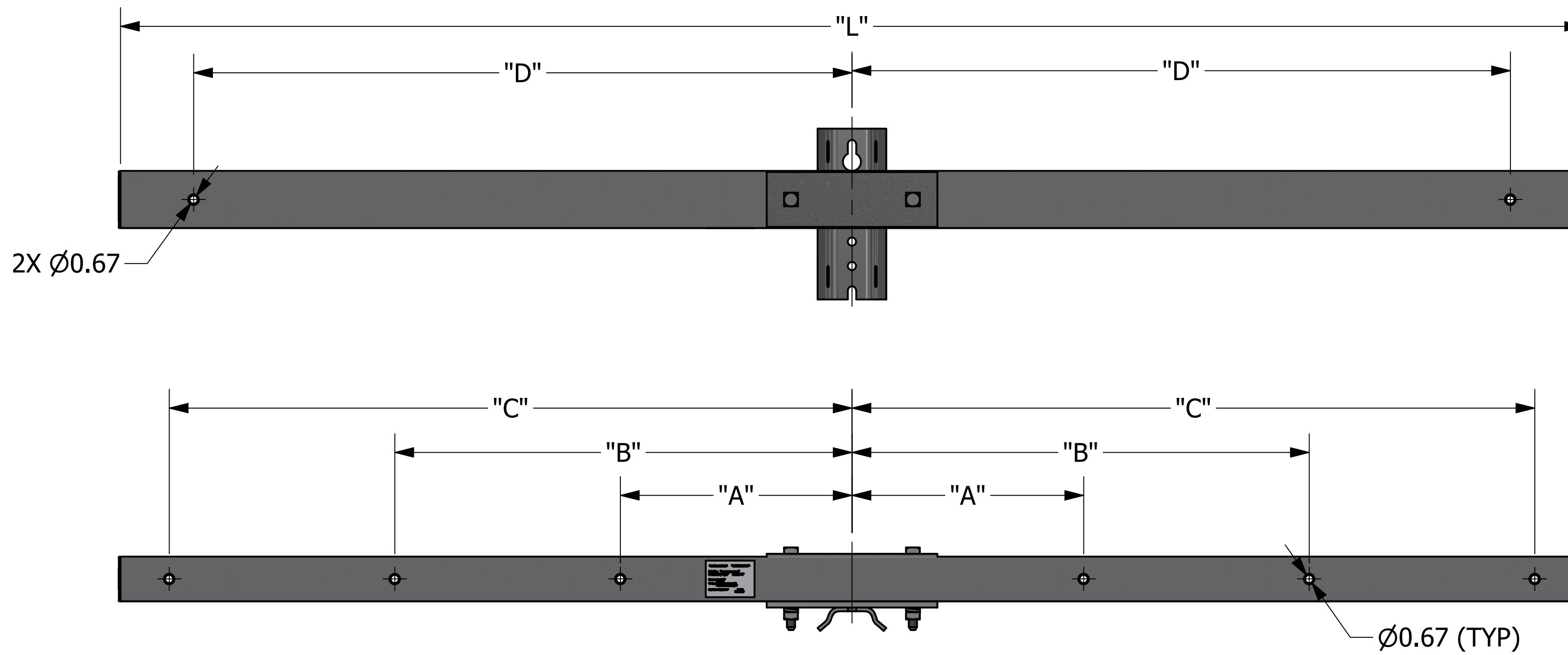
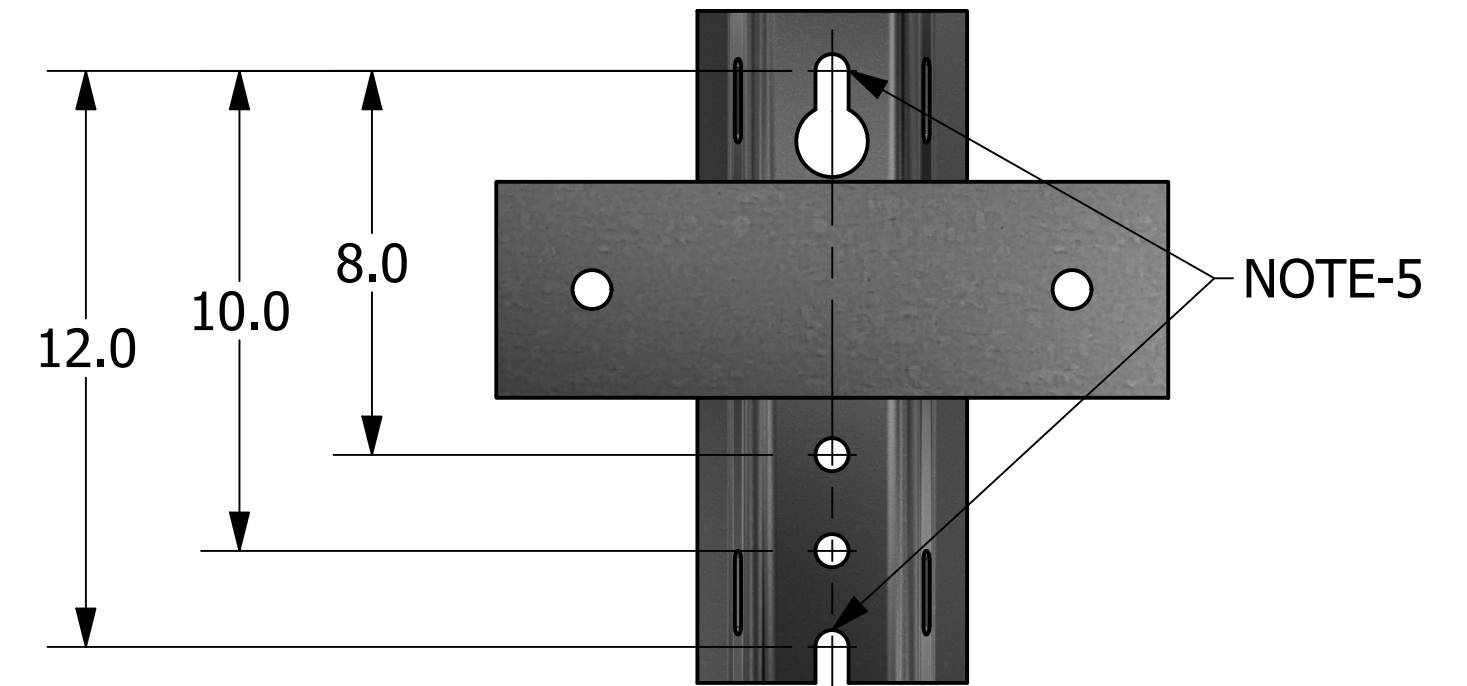

CATALOG NUMBER (NOTE-6)	RUS DRILL PATTERN	"L"	"A"	"B"	"C"	"D"	NO. OF WIRES	ULTIMATE RATING (PER WIRE)
CTA20G096N4003B	03	96"	15"	N/A	44"	42"	4	3,500 LBS
CTA20G096N6004B	04	96"	15"	29.5"	44"	42"	6	2,250 LBS
CTA20G120N4007B	N/A	120"	19"	N/A	56"	54"	4	3,375 LBS
CTA20G120N6005B	05	120"	19"	37.5"	56"	54"	6	2,250 LBS
CTA20G144N4008B	N/A	144"	38"	N/A	66"	68"	4	3,250 LBS
CTA20G144N4009B	N/A	144"	38"	53"	66"	68"	6	2,150 LBS

<b>CHANCE</b> <sup>®</sup>	<b>HUBBELL</b> <sup>®</sup> HUBBELL POWER SYSTEMS, INC. POWER SYSTEMS, INC.			
	TITLE <b>FIBERGLASS TANGENT ARM 20 SERIES</b>			
CONFIDENTIAL: THIS DRAWING AND ITS CONTENTS ARE CONFIDENTIAL AND THE EXCLUSIVE PROPERTY OF HUBBELL POWER SYSTEMS. NO PUBLICATION, DISTRIBUTION, OR COPIES MAY BE MADE WITHOUT THE WRITTEN CONSENT OF HUBBELL POWER SYSTEMS. HUBBELL POWER SYSTEMS UNPUBLISHED ALL RIGHTS RESERVED UNDER THE COPYRIGHT LAWS.	SIZE <b>C</b>	CAT / PART / ASSY NO. <b>SEE CHART</b>	DWG NO. <b>SACTX20</b>	REV <b>A</b>
DO NOT SCALE THIS DRAWING	DRN BY HOEK	DATE 4/29/24	SHEET 1 OF 2	

# HPS 20 SERIES FIBERGLASS TANGENT SMART NUMBERING SYSTEM

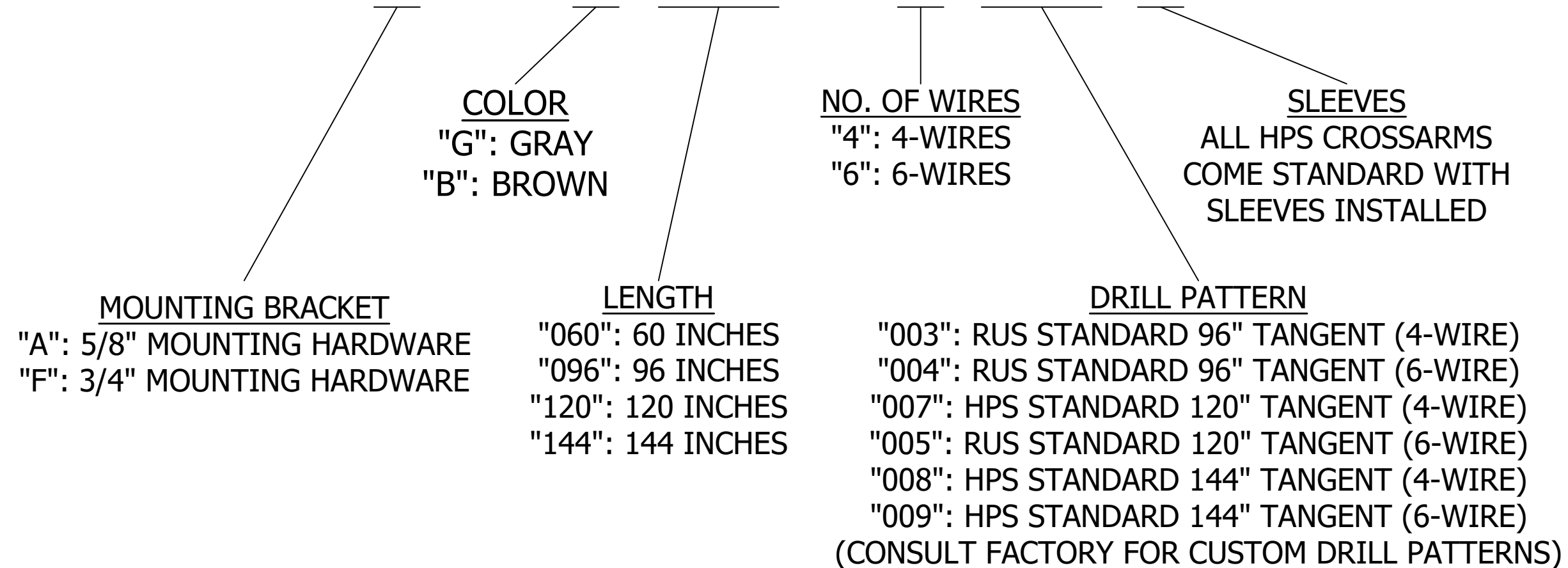
**CT A 20 G 096 N 4 003 B**



<b>CHANCE</b> <sup>®</sup>	 <b>HUBBELL POWER SYSTEMS, INC.</b>			
	TITLE <b>FIBERGLASS TANGENT ARM 20 SERIES</b>			
CONFIDENTIAL: THIS DRAWING AND ITS CONTENTS ARE CONFIDENTIAL AND THE EXCLUSIVE PROPERTY OF HUBBELL POWER SYSTEMS. NO PUBLICATION, DISTRIBUTION, OR COPIES MAY BE MADE WITHOUT THE WRITTEN CONSENT OF HUBBELL POWER SYSTEMS. HUBBELL POWER SYSTEMS UNPUBLISHED ALL RIGHTS RESERVED UNDER THE COPYRIGHT LAWS.	SIZE <b>C</b>	CAT / PART / ASSY NO. <b>SEE CHART</b>	DWG NO. <b>SACTX20</b>	REV <b>A</b>
DO NOT SCALE THIS DRAWING	DRN BY HOEK	DATE 4/29/24	SHEET 2 OF 2	